



2500 series

Single, Dual, Triple Output DC/DC Converter



DESCRIPTIONS

The 2500 series is a family of compact 25W, high performance DC/DC converters which offer a wide variety of standard input/output voltage combinations. The 2500 series operate over 2:1 input ranges of 9 to 18, 18 to 36 or 36 to 72 VDC; providing single, dual or triple output combinations of 5, 6, 12, 15, ± 5 , ± 12 , 5 ± 12 and 5 ± 15 VDC. All models have been approved to UL 1950 and CSA 22.2 safety standards.

OUTPUT CHARACTERISTICS

	Min	Typ	Max	Unit/Comments
Output Voltage Accuracy				
Single & Dual Outputs			± 1.0	% ¹
Triple Outputs - Primary			± 1.0	% ¹
- Auxiliaries			± 5.0	% ¹
Output Voltage Adjustment			± 5.0	% ¹
Voltage Balance:				
Dual Outputs	± 0.5	± 1.0		%; Equal Output Loads
Triple Outputs (Auxiliaries)	± 50	± 100		mV; Equal Output Loads
Minimum Load			10%	Full Load
Line Regulation				
Single Outputs	± 0.2	± 0.5		% ²
Dual Outputs	± 0.4	± 1.0		% ²
Triple Outputs - Primary	± 0.2	± 0.5		% ²
- Auxiliaries	± 1.0	± 5.0		% ²
Load Regulation				
Single Outputs			± 0.5	% ³
Dual Outputs	± 0.5	± 1.0		% ³ ; Equal Loads
Triple Outputs - Primary	± 0.5	± 1.0		% ³
- Auxiliaries			± 5.0	% ³ ; Equal Loads
Ripple/Noise				
5V Outputs		75		mV; p-p, Nom.Line FL, 20Mhz B.W. using 1 μ f bypass capacitor
12V and 15V Outputs		1		% of Vout
Short Circuit Protection				Continuous, Automatic Recovery
Temperature Coefficient		± 0.02		% per °C
Over Voltage Protection				See Model Selection Guide

FEATURES

- 6 sided Continuous Shielding
- Synchronization and Output Trim
- Efficiency to 86%
- Wide 2:1 Input Voltage Range
- Input Pi Filter
- UL 1950 Approved
- CSA 22.2 Approved
- Remote On/Off Control

INPUT CHARACTERISTICS

	Min	Typ	Max	Unit/Comments
Input Voltage Range				
12 VDC Input Models	9	12	18	VDC
24 VDC Input Models	18	24	36	VDC
48 VDC Input Models	36	48	72	VDC
Remote On / OFF Control				
Supply ON				5.5 VDC or Open Circuit
Supply OFF				0 VDC to 0.8 VDC
Logic Referenced to Negative Input				
Reverse Polarity Input Current			12	Amp
Input Filter				Pi Filter
Input Fuse Rating				See Model Selection Guide

GENERAL CHARACTERISTICS

	Min	Typ	Max	Unit/Comments
Switching Frequency	100			kHz
Isolation Voltage	500			VDC, 1 minute
Isolation Resistance	1000			Mohm, 500VDC
MTBF (MIL-HBK-217F)	700			Thousand Hours, +25°C, Ground Benign

¹ = Output voltage at nominal line & FL

² = % Output voltage measured from min. input line to maximum

³ = Output voltage measured from FL to 10% Load

Martek Power reserves the right to change specifications without notice.



ENVIRONMENTAL SPECIFICATIONS

	Min	Typ	Max	Unit/Comments
Operating Temp. Range	-30		+75	°C; Ambient
Storage Temp. Range	-40		+125	°C
Relative Humidity			95	% Humidity; non-condensing
Cooling				Free-Air Convection

PHYSICAL CHARACTERISTICS

	Unit/Comments
Case Size	2.56 X 3.0 X 0.75 inches (65.0 X 76.2 X 19.0 mm)
Case Material	Coated Metal with Non-Conductive Base
Shield Connection	
12V and 24V Input Models	Negative Input, Pin 3
48V Input Models	Positive Input, Pin 2
Flammability	UL94V-0
Weight	227 Grams

OUTLINE DRAWING

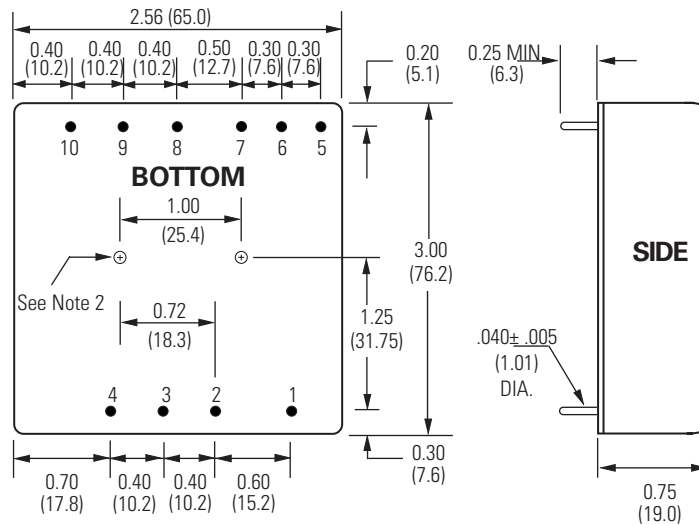

PIN OUT CHART

Pin	Single	Dual	Triple
1	Remote On/Off	Remote On/Off	Remote On/Off
2	+ Vin	+ Vin	+ Vin
3	- Vin	- Vin	- Vin
4	Sync	Sync	Sync
5	+Sense/Trim(Down)*	+ Vout	+ Vout (Aux)
6	Output Trim	Common	Common(Aux)
7	- Sense/Trim(Up)*	- Vout	- Vout (Aux)
8	+ Vout*	Output Trim	+5V Vout
9	- Vout*	No Pin	- 5V Vout
10	No Pin	No Pin	Output Trim

* Connections for single output models without sensing or external trimming:
 For proper operation, externally connect Pin 5 (+Sense) to Pin 8 (+Vout) and Pin 7 (-Sense) to Pin 9 (-Vout)

Notes:

- Unless otherwise specified dimensions are in inches (mm).
 Tolerances Inches mm
 X.XX = ±0.02 X.X = ±0.5
 X.XXX = ±0.010 X.XX = ±0.25
- Mounting inserts: 4-40 X .10 (2.5) Deep

All specifications are typical at nominal input, nominal load and 25° C unless otherwise specified.
 External, low ESR, 10 microfarad (minimum) capacitor across output is recommended for operation.

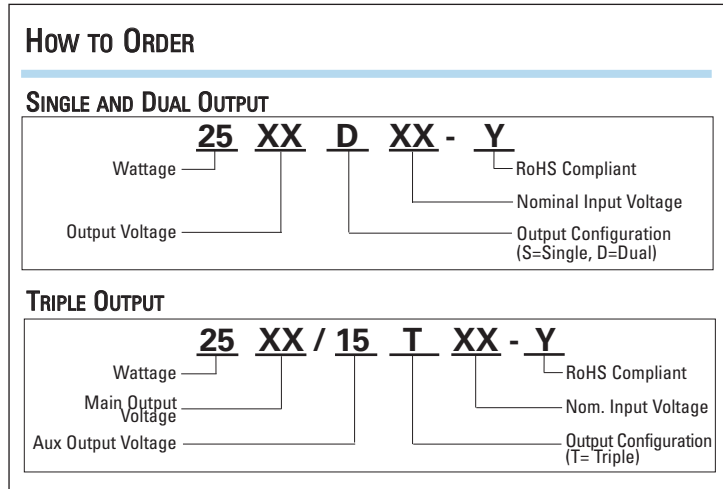

MODEL SELECTION CHART

Model	Nominal Input Voltage (VDC)	Output Voltage (VDC)	Full Load Output Current (mA)	No Load Input Current (mA)	Full Load Input Current (mA)	Output Over Voltage (VDC)	Fuse (A)	Efficiency @ FL (%)
2505S12	12	5	5000	30	2750	6.5	5.0	76
2506S12	12	6	4000	30	2700	7.5	5.0	74
2512S12	12	12	2000	30	2670	15.0	5.0	75
2515S12	12	15	1650	30	2700	18.0	5.0	74
2505D12	12	±5	±2500	40	2770	±6.5	5.0	75
2512D12	12	±12	±1000	40	2670	±15.0	5.0	75
2515D12	12	±15	±800	40	2670	±18.0	5.0	75
2505S24	24	5	5000	30	1300	6.5	2.5	80
2506S24	24	6	4000	30	1250	7.5	2.5	80
2512S24	24	12	2000	30	1280	15.0	2.5	78
2515S24	24	15	1600	30	1280	18.0	2.5	78
2505D24	24	±5	±2500	30	1330	±6.5	2.5	78
2512D24	24	±12	±1000	30	1280	±15.0	2.5	78
2515D24	24	±15	±800	30	1280	±18.0	2.5	78
2505S48	48	5	5000	15	630	6.5	1.5	83
2506S48	48	6	4000	15	590	7.5	1.5	85
2512S48	48	12	2000	15	625	15.0	1.5	80
2515S48	48	15	1600	15	640	18.0	1.5	78
2505D48	48	±5	±2500	15	650	±6.5	1.5	80
2512D48	48	±12	±1000	15	625	±15.0	1.5	80
2515D48	48	±15	±800	15	625	±18.0	1.5	80
2505/12T12	12	5, ±12	2500, ±520	40	2770	6.5, ±15.0	5.0	75
2505/15T12	12	5, ±15	2500, ±415	40	2770	6.5, ±18.0	5.0	75
2505/12T24	24	5, ±12	2500, ±520	30	1300	6.5, ±15.0	2.5	80
2505/15T24	24	5, ±15	2500, ±415	30	1300	6.5, ±18.0	2.5	80
2505/12T48	48	5, ±12	2500, ±520	15	640	6.5, ±15.0	1.5	81
2505/15T48	48	5, ±15	2500, ±415	15	640	6.5, ±18.0	1.5	81



OUTPUT VOLTAGE ADJUSTMENT (2500 SERIES - SINGLE OUTPUT)

The converter's output voltage may be trimmed by up to ±10% of the nominal output voltage.

TRIM UP

Trim output voltage up by connecting an external resistor between Pins 6 and 7/9. Use the following equation, reference Table 1 for variables A and B.

$$R_{adj-up} = \frac{A}{\Delta \%} - B \text{ (k}\Omega\text{)}$$

Example:

Trim both outputs 5% up for 12V Output units, where A = 2.01, B = 24, Δ % = 0.05

$$R_{adj-up} = \frac{2.01}{0.05} - 24 \text{ k}\Omega = 16.2 \text{ k}\Omega$$

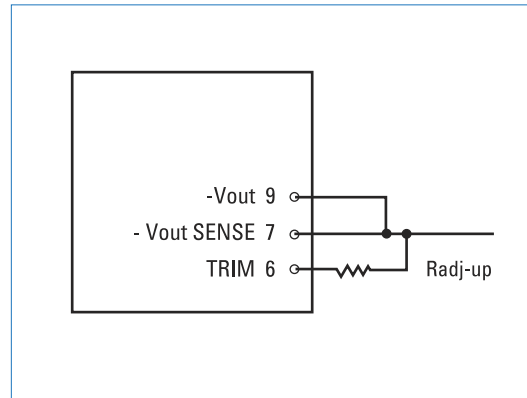

Table 1.

Output Voltage	A	B
5V	1.28	24
6V	1.49	24
12V	2.01	24
15V	2.12	24

TRIM DOWN

Trim output voltage down by connecting an external resistor between Pins 6 and 5/8. Use the following equation, reference Table 2 for variables C and D.

$$R_{adj-down} = \frac{C}{\Delta \%} - D \text{ (k}\Omega\text{)}$$

Example:

Trim 2% down for 5V Output units, where C = 1.27, D = 26.6, Δ % = 0.02

$$R_{adj-down} = \frac{1.27}{0.02} - 26.6 \text{ k}\Omega = 36.9 \text{ k}\Omega$$

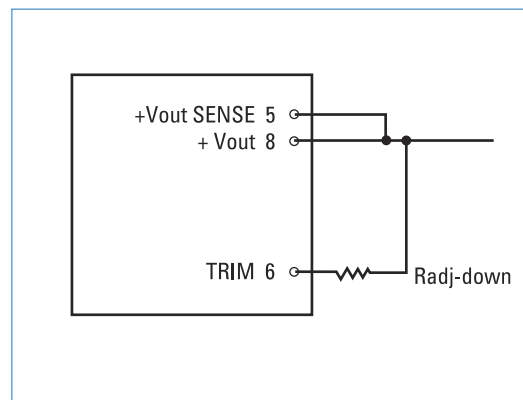

Table 2.

Output Voltage	C	D
5V	1.27	26.6
6V	2.08	27.6
12V	7.5	33.5
15V	10.3	36.4



OUTPUT VOLTAGE ADJUSTMENT (2500 SERIES - DUAL OUTPUT)

The converter's output voltage may be trimmed by up to ±10% of the nominal output voltage.

TRIM UP

Trim both output voltages up by connecting an external resistor between Pins 7 and 8. Use the following equation, reference Table 1 for variables A and B.

$$\text{Radj-up} = \frac{A}{\Delta \%} - B \text{ (k}\Omega\text{)}$$

Example:

Trim both outputs 5% up for 12V Output units, where A = 2.28, B = 24, Δ % = 0.05

$$\text{Radj-up} = \frac{2.28}{0.05} - 24 \text{ k}\Omega = 21.6 \text{ k}\Omega$$

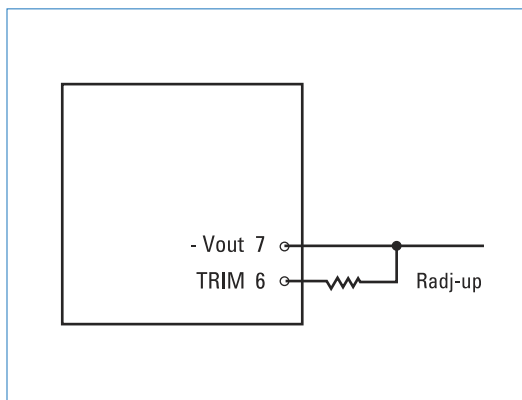

Table 1.

Output Voltage	A	B
5V	1.90	24
12V	2.28	24
15V	2.33	24

TRIM DOWN

Trim both output voltages down by connecting an external resistor between Pins 5 and 8. Use the following equation, reference Table 2 for variables C and D.

$$\text{Radj-down} = \frac{C}{\Delta \%} - D \text{ (k}\Omega\text{)}$$

Example:

Trim 5% down for 5V Output units, where C = 5.60, D = 31.5, Δ % = 0.05

$$\text{Radj-down} = \frac{5.60}{0.05} - 31.5 \text{ k}\Omega = 80.5 \text{ k}\Omega$$

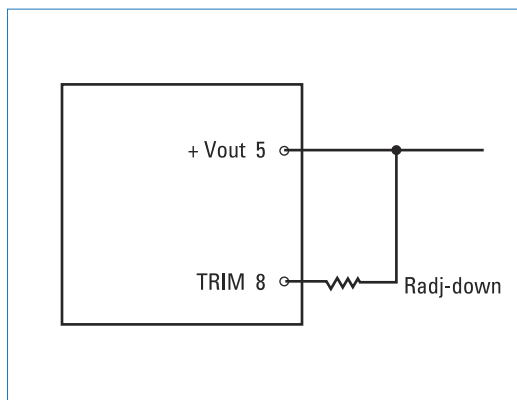

Table 2.

Output Voltage	C	D
5V	5.60	31.5
12V	19.2	45.5
15V	25.1	51.4



OUTPUT VOLTAGE ADJUSTMENT (2500 SERIES - TRIPLE OUTPUT)

The converter's output voltage may be trimmed by up to $\pm 10\%$ of the nominal output voltage.

TRIM UP

Trim all 3 output voltages up by connecting an external resistor between Pins 9 and 10. Use the following equation.

$$\text{Radj-up} = \frac{1.28}{\Delta \%} - 24 \text{ (k}\Omega\text{)}$$

Example:

Trim all 3 outputs 5% up for units where $\Delta \% = 0.05$

$$\text{Radj-up} = \frac{1.28}{0.05} - 24 \text{ k}\Omega = 1.6 \text{ k}\Omega$$

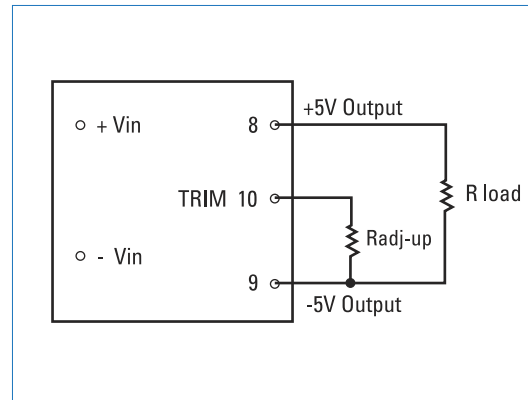

TRIM DOWN

Trim all 3 output voltages down by connecting an external resistor between Pins 8 and 10. Use the following equation.

$$\text{Radj-down} = \frac{1.28}{\Delta \%} - 26.6 \text{ (k}\Omega\text{)}$$

Example:

Trim all 3 outputs 3% down where $\Delta \% = 0.03$

$$\text{Radj-down} = \frac{1.28}{0.03} - 26.6 \text{ k}\Omega = 16.1 \text{ k}\Omega$$

